

COMMERCIAL FRAMING | SERIES 600  
WIDE OFFSET 150mm FRAMING

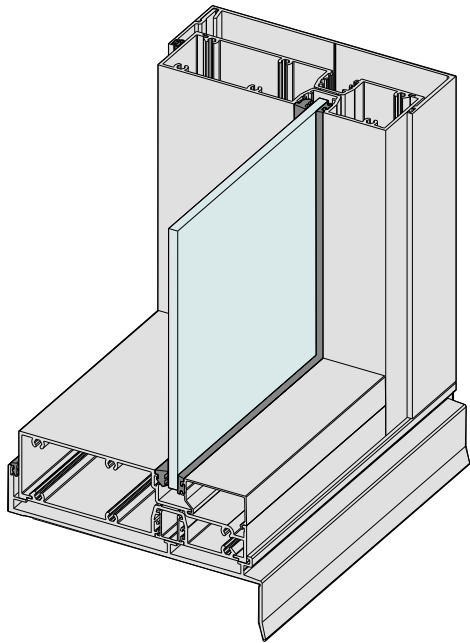

KEY FEATURES

- Series 600 wide shopfront framing is 150mm thick by 44mm wide with the glazing pocket offset. The product is ideal for frames spanning more than 3m high.
- The glazing pocket is set forward to allow use of 102mm or 80mm transoms from Series 400 and Series 80.
- We can fit a true captive glazing wedge on one side. This reduces the chance of vandalism.
- External wet top silicone glazing also available.
- There are several custom designed extrusions to cater for specific applications.
- Sub-sill included as we always recommend sub-sills under commercial framing.
- Sub-head to allow for building settlement.
- Two piece sub-jamb to simplify installation.
- Hinged door threshold.
- Will accept awning sashes or sliding sashes.
- Compatible with Series 50, 51 and 52 doors.

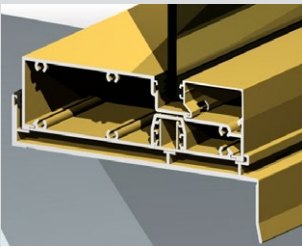

150mm offset glazing that maintains glazing line to Series 400 and 80 suites. Sub-sill has additional support leg under glass, to carry weight of heavy glass preventing frame dishing.

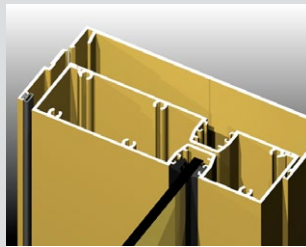

Sub-sill, sub-head and sub-jamb available.

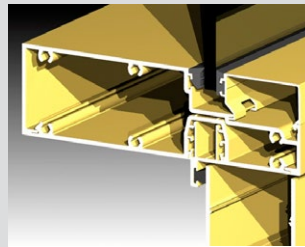

This detail shows the standard 150mm wide transom from Series 600. We can also fit the narrower transoms for Series 400 (102mm) or Series 80 (80mm).

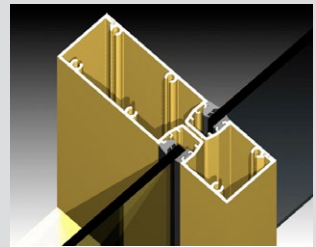

Various mullion details for site wind load conditions. We recommend expansion mullions on long runs of framing (over 6m).

GENERAL

**Max Panel Height**  
Various

**Max Panel Width**  
Various

**Max Glass Thickness**  
10.38mm

**Frame Depth**  
150mm

ENERGY

**UW Range**  
4.5-6.4

**SHGC Range**  
0.33-0.63

WEATHER

**Maximum Water**  
600 Pa.

Based on tests carried out on Series 400.

ACOUSTICS

**6.5mm VLam Hush™**  
Rw 34 (0;-3)

**10.50mm VLam Hush™**  
Rw 37 (0;-3)

**10.38mm Lam**  
Rw 34 (-1;-2)

**6.38mm Lam**  
Rw 32 (-2;-3)

Based on tests carried out on Series 400 - similar system.



BAL-40 compliance may limit glass options. Maximum glass size for BAL-40 products is 5m².

[elevatealuminium.com.au/600](http://elevatealuminium.com.au/600)